

Revision						
ISSUE	Mark	Contents	Design	Check	Appro	DATE
1.0	▲	xx → xx				2006. 12. 03

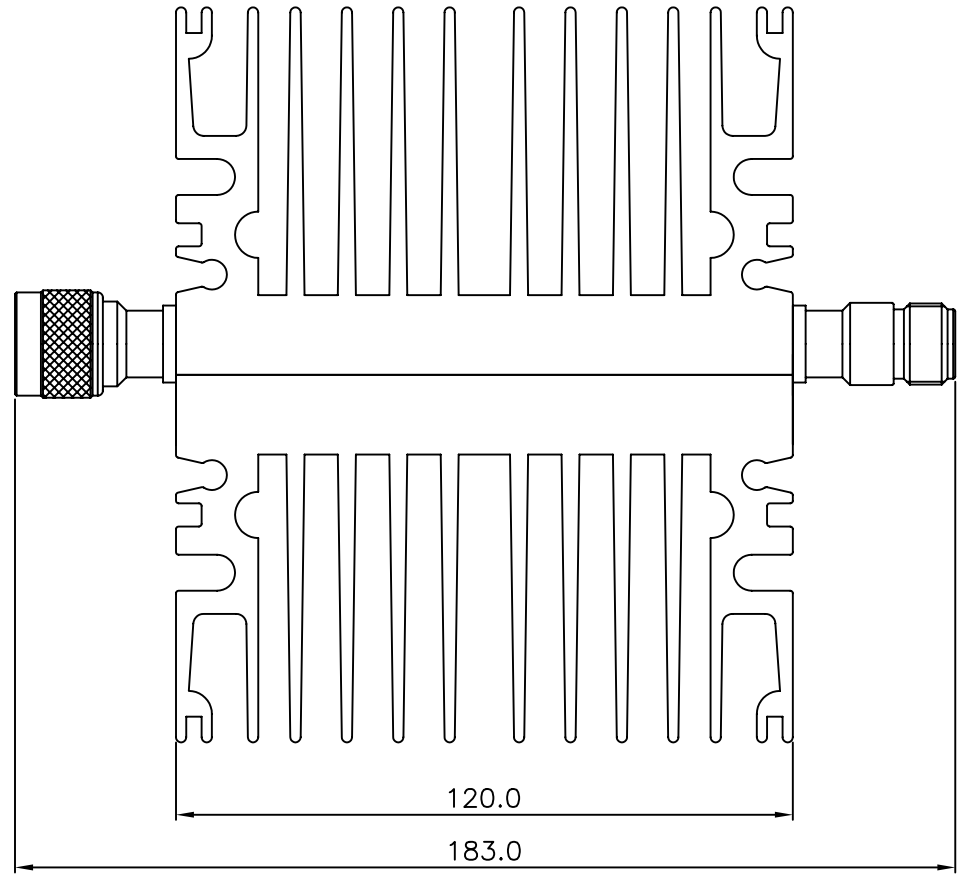
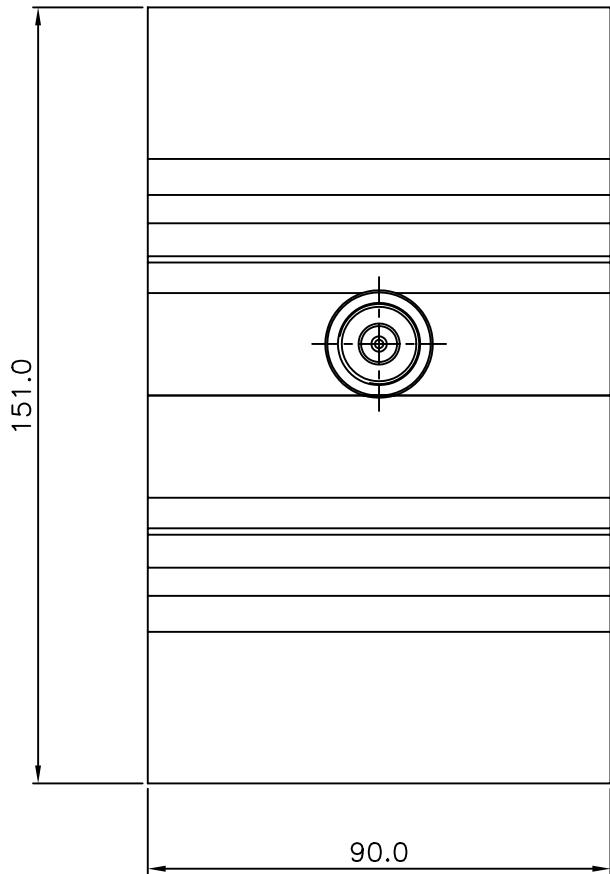

ELECTRICAL SPECIFICATIONS

- | | |
|--------------------------|---------------------------|
| 1. Frequency Range (MHz) | DC to 3 Ghz |
| 2. Impedance (Nominal) | 50 Ohms |
| 3. V.S.W.R (Max.) | 1.25 |
| 4. Attenuation | 10, 20, 30, 40dB |
| 5. Accuracy | ± 1.0dB |
| 4. Power Rating | AVG. 150 watt
Peak 2Kw |

MECHANICAL SPECIFICATIONS

- Connector Body : Brass
SuCo Plated
- Connector Contact : Brass
Gold Plated
- Housing : Aluminum
Black Anodized

No.	Description	Code	Q'ty	Material	Finish
	Specified Tolerance	Mat'l	AL6061		
0.	±0.3	Finish	 CROSS RF SOLUTIONS		
.0	±0.1				
.00	±0.05	Design	Check	Appro	Model
ANG.	±0°30'				HIGH POWER ATTENUATOR
Scale	Unit	Proj	Size	Title	N Plug-Jack (150watt)
1/1	mm	▲4		Mod.No.	
			070213	Part No.	FA-N150